

# Community Integration Model

## Phasing Overview

Phase One:

- Increased Community Supports
- Development of a Supportive Housing Complex

Phase Two:

- Conversion Nursing Home unit to Convalescent Care and Short Term Behavioural Assessment Unit

Phase Three:

- Conversion WPSHC Complex Continuing Care Unit to a Geriatric Rehabilitation Unit with a maximum stay of six months

## Model Overview

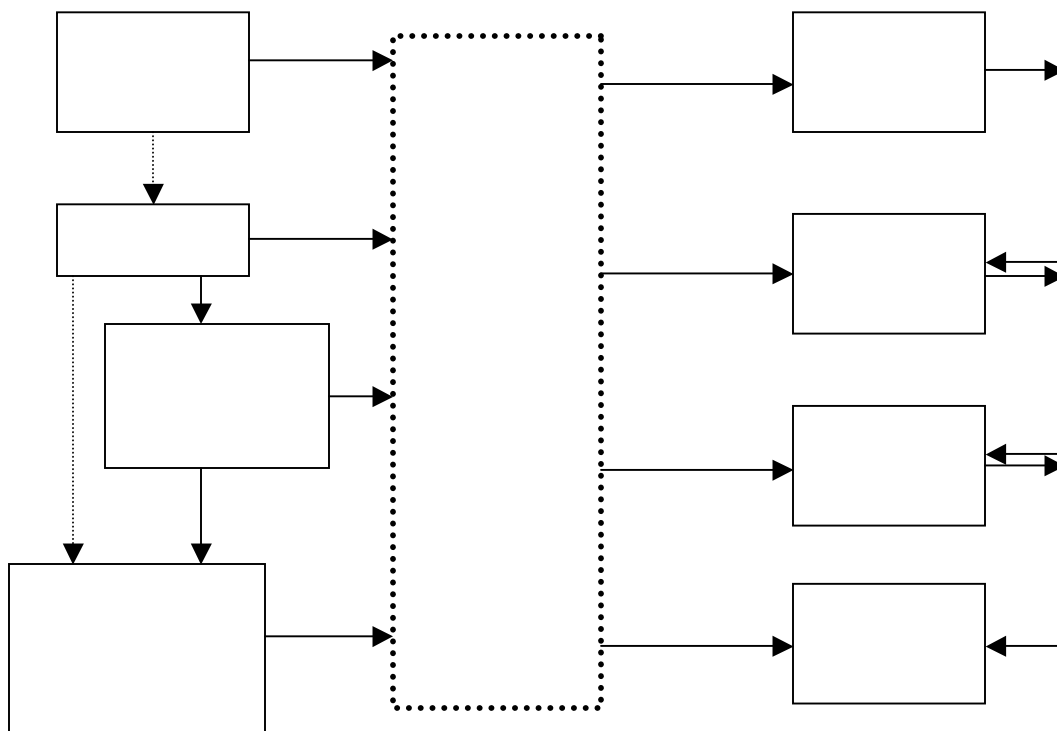

## **Derived Outcomes**

- 1) Once the Supportive Housing Complex is developed, it allows for the conversion of a portion of Nursing Home Beds to Convalescent Care and Short Stay Behavioral Assessment Unit, which will allow Complex Continuing Care to convert to a short stay Geriatric Rehabilitation Unit.
- 2) Once the Flow-Through Facility Process is in place, it:
  - ensures optimum utilization of LTC beds
  - decreases or potentially eliminates the need for additional LTC beds.
  - Focuses Nursing Home to “end of life” care and dementia/behavioural care.
- 3) Dramatically decreases demands on acute care beds